

MK Series - High Performance Butterfly Valves

Operation and Maintenance Instructions

11/19/21

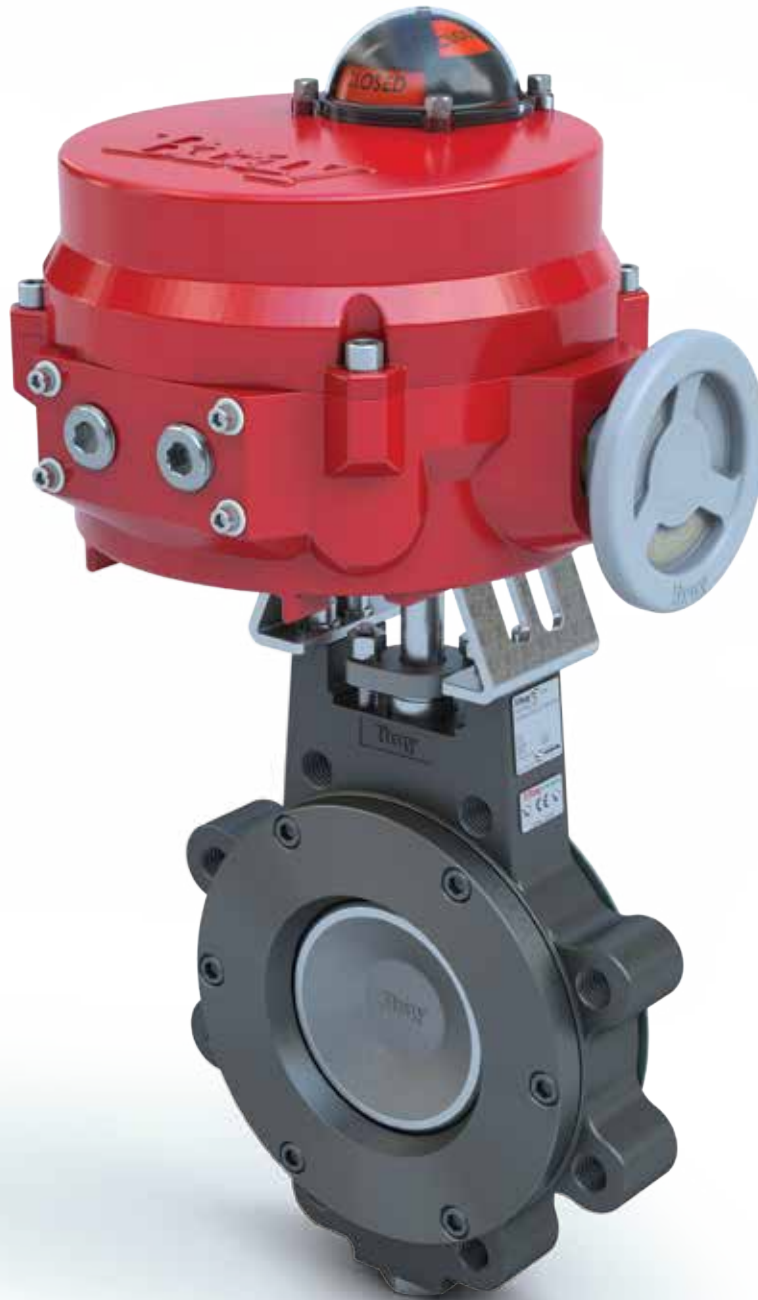

MK Series - Operation and Maintenance Instructions



TABLE OF CONTENTS:

	PAGE
SAFETY INSTRUCTIONS & DEFINITION OF TERMS	3
INTRODUCTION	3
INSTALLATION	3
MAINTENANCE	4
VALVES WITH SPRING RETURN ACTUATOR	4
INSTALLATION ORIENTATION	5
VALVE LOCATION AND ORIENTATION IN PIPING	5
VALVE ORIENTATION DIAGRAMS	6,7
INSTALLATION CONSIDERATIONS	8
MAINTENANCE & REPAIR	9
MK FIELD ADJUSTMENTS	10
MK PARTS DIAGRAM	11

FOR INFORMATION ON THESE PRODUCTS AND OTHER BRAY PRODUCTS
PLEASE VISIT US AT OUR WEB PAGE - www.braycommercialdivision.com

MK Series - Operation and Maintenance Instructions

Safety Instructions - Definition of Terms read and follow these Instructions - Save these Instructions

	WARNING	indicates a potentially hazardous situation which, if not avoided, could result in death or serious injury.
	CAUTION	indicates a potentially hazardous situation which, if not avoided, may result in minor or moderate injury.
	NOTICE	used without the safety alert symbol indicates a potential situation which, if not avoided, may result in an undesirable result or state, including property damage.

INTRODUCTION

The MK high-performance butterfly valve combines the advantages of trunnion-type ball valves with the easy operation, light weight, and low cost of butterfly valves. One basic design is suitable for a wide range of services, including oxygen, chlorine, vacuum, water and steam applications.

Features Include:

- Bubble tight shutoff provided throughout a wide range of operating conditions.
- Suitable for both modulating and on/off services, the MK Series butterfly valve is easily automated with your choice of manual operators, electric and pneumatic actuators, positioners, and controls.
- The MK Series is available in a Fire Safe model qualified to API 607 5th Edition and BS 6755 Part 2.
- The MK Series is also available in a Metal Seated only model providing IEC 60534-4 Class IV bi-directional leakage rates through full pressure range.

Additional information about the MK Series butterfly valves – including application data, engineering specifications, and actuator selection is available at braycommercialdivision.com or from your Bray distributor or sales representative.

INSTALLATION

1. The MK Series valve is designed to be mounted between ANSI flanges. When the valve is open, the disc will extend into the pipe on both sides of the valve – further on the body side than the seat retainer side of the valve. Piping must be large enough to allow the disc to clear the pipe. Tables 1 and 2 on page 5 show the minimum pipe ID

allowable, and standard pipe IDs. In general, Class 150 valves will clear Schedule 40 pipe, and Class 300 valves will clear Schedule 80 pipe adequately.



CAUTION

2. If handle or actuator has been removed do not rotate disc beyond full open or closed position – this could cause damage to sealing surfaces.

NOTE: The Mk Series valves are equipped with travel limiters to prevent over closure. The valve is opened by turning counterclockwise, closed by turning clockwise. The double “D” flats or keyway at the top of the stem is parallel to the disc edge.

NOTICE

3. For maximum service life, install the valve with the seat retainer upstream. Positive shutoff will be obtained with the valve in either position; however, installation with the seat retainer upstream will give longer service life, especially in erosive services.
4. With the disc in closed position, carefully center valve between flanges. Guide holes (wafer pattern valve) or tapped holes (lugged valves) to match ANSI Pipe flanges and assist in positive alignment.
5. Use standard torques when bolting valve into the line. The seat is sufficiently compressed by the seat retainer, and additional force from flange bolting is not required.
6. Gaskets should conform to the requirements of API Standard 601, Edition 3 for ASME/ANSI B16.5 class flanges. Spiral wound gaskets, such as Flexitallic CG or CGI series, conforming to ASME/ANSI B16.20 are acceptable.

MK Series - Operation and Maintenance Instructions

Installation Considerations – Piping and Valve Orientation and Placement

MAINTENANCE

1. Reasonable precautions should be taken before beginning work on the valve. Protective clothing, as required by the specific line fluid, should be worn.



WARNING

Before removing handle or the actuator from the valve, or before removing seat retainer from a valve in dead end service, close the valve and depressurize the line.

2. The eccentric design of the Bray MK Series may allow line pressure to open the valve if the handle/actuator is not in place while the valve is under pressure.



WARNING

Do not pressurize the line without a handle or actuator on the valve.

3. The Bray MK Series valve must be in the closed position to be removed from the line.
4. Begin all work on a valve that has been removed from the line by cleaning the valve, removing any grit or scale.



CAUTION

When handling the valve, care should be taken not to scratch the disc edge or seat.

5. Replacement seats, seals and other parts are available from authorized distributors. Contact your distributor or sales representative for details of price and delivery.

NOTES:

1. Minimum ID of pipe with recommended clearances (per API 609) have been calculated by adding the minimum ID with zero clearance to a minimum recommended diametric clearance for each pipe size.
2. These charts assume that the pipe is on the body side of the valve and that the pipe is perfectly centered. The seat retainer side of the valve will always have more clearance than the body side.
3. A minimum of 1/16" thick gasket is used between the pipe flange and valve body face.
4. When using a pipe whose ID is smaller than the recommended minimum inside diameter of pipe with adequate clearance, a chamfer of 45° should be provided on the end of the pipe so that it clears the disc.

Valves with Spring Return Actuators

1. Fail Closed Assemblies

If the valve is supplied with an actuator, the butterfly valve is shipped in the full closed position (as no air pressure is present to compress the springs and open the disc).

2. Fail Open Assemblies

If the valve is supplied with an actuator, the butterfly valve disc is shipped in the full open position (as no air pressure is present to compress the springs and close the valve disc.) The sealing surface, or disc edge, is therefore exposed. Damage to that surface will cause premature seat failure.

Installation Considerations – Piping and Valve Orientation and Placement

1. Valve Location

- a. MK Series butterfly valves should be installed if possible a minimum of 6 pipe diameters from other line elements, i.e., elbows, pumps, valves, etc. of course, 6 pipe diameters are not always practical, but it is important to achieve as much distance as possible.
- b. Where the MK Series butterfly valve is connected to a check valve or pump, use an expansion joint between them to ensure the disc does not interfere with the adjacent equipment.

MK Series - Operation and Maintenance Instructions

2. Valve Orientation

a. In general, Bray recommends the MK Series valve be installed with the stem in the vertical position and the actuator mounted vertically directly above the valve; however, there are those applications as discussed below where the stem should be horizontal.

b. For slurries, sludge, mine tailing, pulp stock, dry cement, and any media with sediment or particles, Bray recommends the MK Series valve be installed with the stem in the horizontal position with the lower disc edge

NOTE: Bray does not recommend valves be installed in an upside-down position.

**Table 1 -
NOMINAL INSIDE DIAMETER OF PIPE**

Valve Size In. (mm)	Pipe Schedule	
	40	80
2.5 (65)	2.469 (62.7)	2.323 (59.0)
3 (80)	3.068 (77.9)	2.900 (73.7)
4 (100)	4.026 (102.3)	3.826 (97.2)
5 (125)	5.047 (128.2)	4.813 (122.3)
6 (150)	6.065 (154.1)	5.761 (146.3)
8 (200)	7.981 (202.7)	7.625 (193.7)
10 (250)	10.020 (254.5)	9.564 (242.9)
12 (300)	11.938 (303.2)	11.376 (289.0)
14 (350)	13.124 (333.4)	12.500 (317.5)
16 (400)	15.000 (381.0)	14.314 (363.6)
18 (450)	16.876 (428.7)	16.126 (409.6)
20 (500)	18.814 (477.9)	17.938 (455.6)

**Table 2 -
MINIMUM INSIDE DIAMETER OF PIPE
WITH THE RECOMMENDED CLEARANCE**

Valve Size In. (mm)	Class	
	150	300
2.5 (65)	2.28 (57.9)	2.28 (57.9)
3 (80)	2.86 (72.6)	2.86 (72.6)
4 (100)	3.72 (94.5)	3.72 (94.5)
5 (125)	4.80 (121.9)	4.80 (121.9)
6 (150)	5.88 (149.4)	5.75 (146.1)
8 (200)	7.80 (198.1)	7.56 (192.0)
10 (250)	9.78 (248.4)	9.44 (239.8)
12 (300)	11.74 (298.2)	11.31 (287.3)
14 (350)	12.90 (327.7)	11.38 (289.1)
16 (400)	14.68 (372.9)	14.31 (363.5)
18 (450)	16.60 (421.6)	15.00 (381.0)
20 (500)	18.50 (469.9)	16.50 (419.1)

SEATING & UNSEATING TORQUES

Valve orientation to the flow of media affects the torque.

Torque values are presented in two categories:

See catalog pages HB-14 through HB-20 for the resulting appropriate actuator sizing.

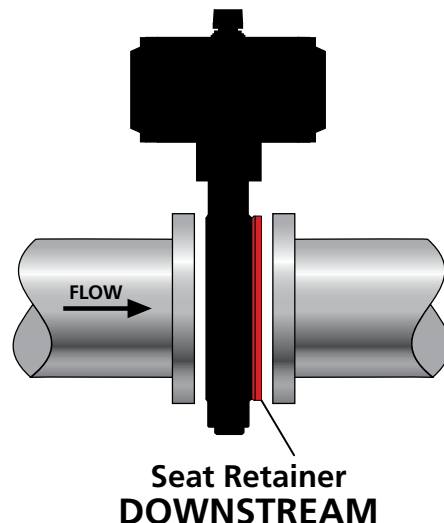
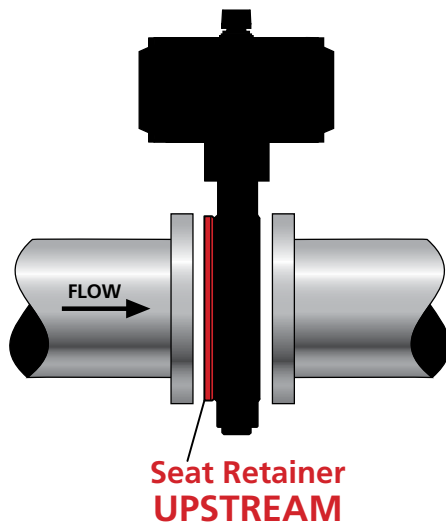

MK Series - Operation and Maintenance Instructions

4. Valve Orientation - Continued

c. MK Series butterfly valve located at the discharge of a pump should be oriented as follows:

	INCORRECT INSTALLATION	CORRECT INSTALLATION
i.) For centrifugal Pump – Pump shaft horizontal and stem vertical	<p>Pump Shaft (Horizontal)</p> <p>FLOW</p> <p>Stem (Horizontal)</p>	<p>Pump Shaft (Horizontal)</p> <p>FLOW</p> <p>Stem (Vertical)</p>
ii.) Centrifugal Pump – Pump shaft vertical & stem horizontal	<p>Pump Shaft (Vertical)</p> <p>FLOW</p> <p>Stem (Vertical)</p> <p>Suction</p>	<p>Pump Shaft (Vertical)</p> <p>FLOW</p> <p>Stem (Horizontal)</p> <p>Suction</p>
iii.) Axial Pump – Pump shaft vertical & stem vertical	<p>Pump Shaft (Vertical)</p> <p>FLOW</p> <p>Stem (Horizontal)</p> <p>Suction</p>	<p>Pump Shaft (Vertical)</p> <p>FLOW</p> <p>Stem (Vertical)</p> <p>Suction</p>

MK Series - Operation and Maintenance Instructions

Installation Considerations – Piping and Valve Orientation and Placement

4. Valve Orientation - Continued

d. Butterfly valves located downstream of a bend or pipe reducer should be oriented as follows:

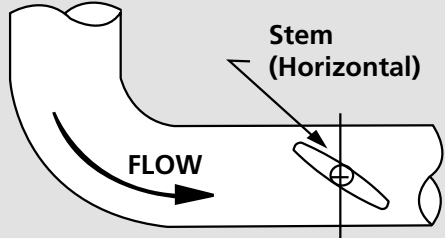
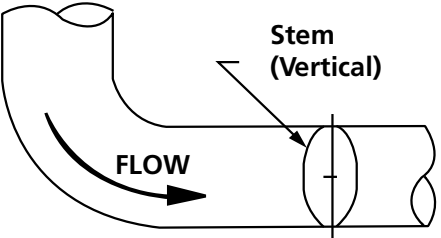
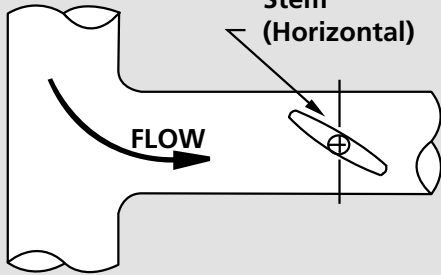
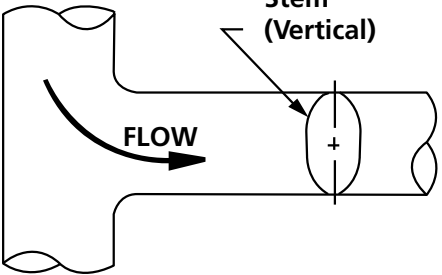
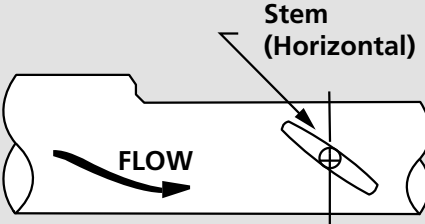
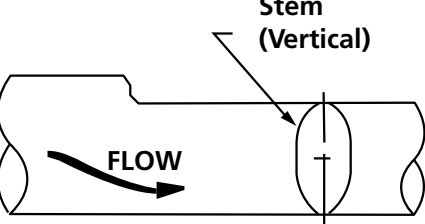
	INCORRECT INSTALLATION	CORRECT INSTALLATION
i.) Bend	 <p>Stem (Horizontal)</p> <p>FLOW</p>	 <p>Stem (Vertical)</p> <p>FLOW</p>
ii.) Tee	 <p>Stem (Horizontal)</p> <p>FLOW</p>	 <p>Stem (Vertical)</p> <p>FLOW</p>
iii.) Pipe Reducer	 <p>Stem (Horizontal)</p> <p>FLOW</p>	 <p>Stem (Vertical)</p> <p>FLOW</p>

MK Series - Operation and Maintenance Instructions

Installation Considerations – Piping and Valve Orientation and Placement

4. Valve Orientation - Continued

e. Butterfly valves in combination for control/isolation applications should be installed as follows:

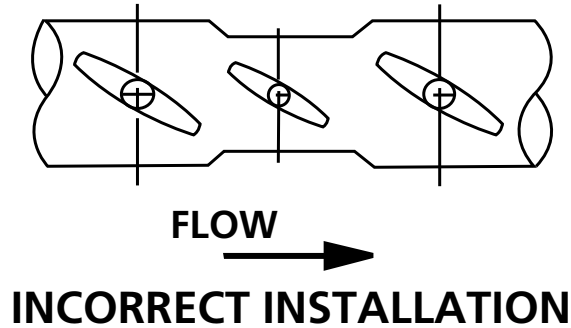

Combination with all valve stems in the same direction accelerates possible noise, vibration, & erosion problems.

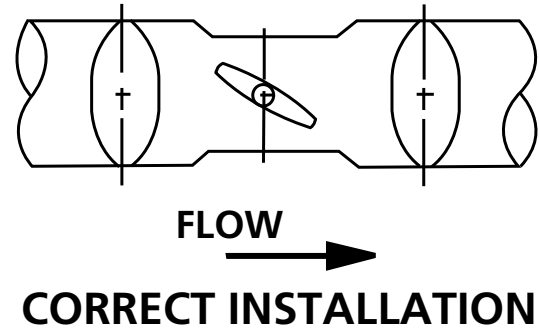

Combination with the stem of the control valve at right angle to those of other valves tends to cancel the drift of the fluid, and reduces noises, vibration, and erosion.



WARNING

Never pick up the valve by the actuator or operator mounted on top of the valve.

Installation Considerations – Lug Style Bolting

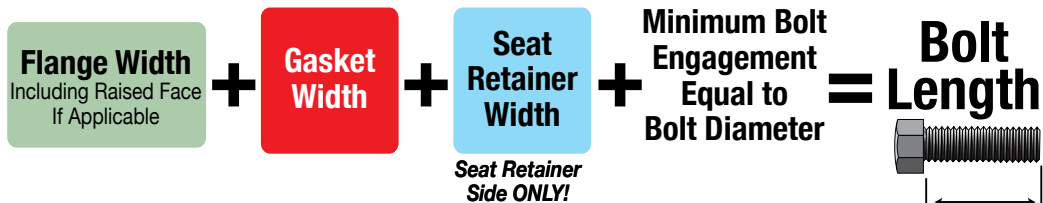
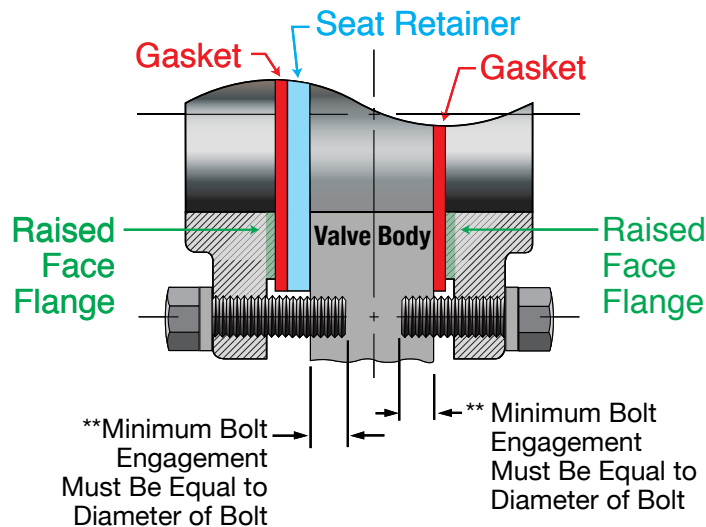

MK Series - Operation and Maintenance Instructions

Figure 1 – Flange Bolt Tightening Pattern

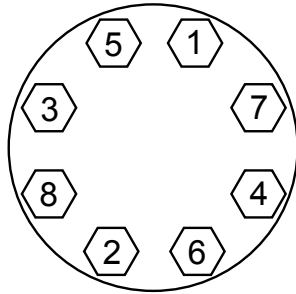
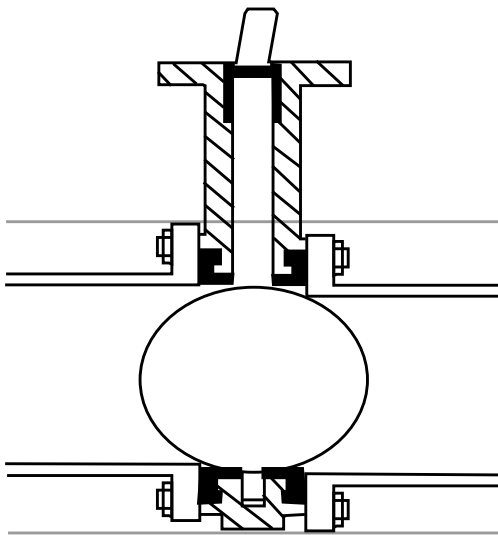
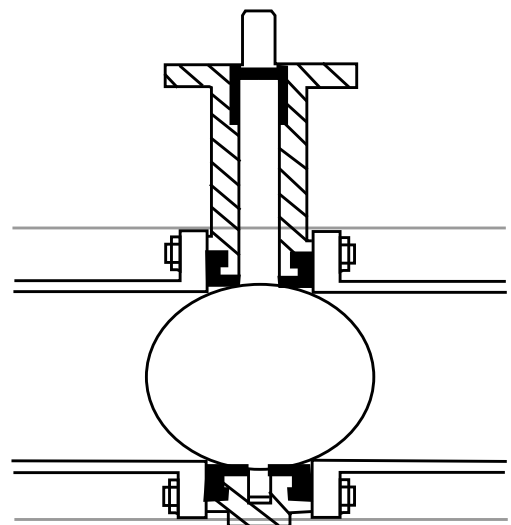

Figure 2 – Final Aligning & Tightening of Flange Bolts



INCORRECT INSTALLATION

Piping misaligned; Results Disc O.D. strikes pipe I.D. causing disc edge damage, increased torque & leakage. Seat face O-rings will not seal properly with incorrectly aligned piping.



CORRECT INSTALLATION

Piping aligned properly when bolts tightened, disc in full open position; Results – disc clears adjacent pipe I.D., seat face seals properly, no excessive initial torque.

Maintenance and Repair

The many Bray features minimize wear and maintenance requirements. No routine lubrication is required.

All components - stem, disc, seat, bushing, stem seal, etc., are field replaceable, no adjustment is required.

If components require replacement, the valve may be removed from the line by placing the disc in the near closed position, then supporting the valve and removing the flange bolts.



WARNING

No valve maintenance, including removal of manual or power actuators, should be performed until the piping system is completely depressurized.

MK Series - Operation and Maintenance Instructions

Field Adjustments

Stem Seal Leakage – Should leakage occur at the stem seals, it may be stopped by retightening the gland retainer nuts.

NOTICE

Do not overtighten gland nuts, as this may cause increased operating torque and improper valve operation or closure.

If the leakage cannot be stopped by this action, the stem seals require replacement.

Adjusting Valve Closure – Valves with gear actuators or electric/pneumatic actuators may require adjustment of the travel stops in the actuator to properly close valve for tight shut-off. The following procedure should be followed to set travel or limit stops. (It is recommended that the valve must be removed from line for this procedure and actuator mounting).

- Using a straight-edge and vernier or depth caliper, measure the distances from the face of the seat retainer to the disc (valve closed) face at the 3 o'clock and 9 o'clock positions (stem is at 12 o'clock position). The measurements must agree within 1/16" (0.062").
- If they do not agree, disc must be rotated in the direction of the larger dimension. If the 3 o'clock dimension is larger, the disc is not fully closed, and must be rotated in the "close" direction more. If 9 o'clock dimension is larger, disc is over-closed, and must be opened slightly.

- The valve disc is at the full open position when the disc is perpendicular to the body. Set the "open" actuator stop for this position.



CAUTION

Do not allow the valve to over-open as this may damage the disc seating surfaces by hitting body or attached piping.

- On gear operators, loosen and adjust the closing stop screw to permit proper disc positioning. Adjust and lock down when disc closure is within measured tolerance in Step 1. Open and close valve; recheck measurements before reinstalling in line.

NOTICE

The setting of the actuation device's close travel stop is important. The valve has an internal travel limiter to ensure valve disc cannot be over closed.

To ensure that the valve travel limiter is not damaged, the actuator close travel stop bolt must be at a position just before valve disc contacts it's travel limiter.

- For other power actuators, consult the manufacturer's instructions for setting travel stops, as these vary with actuator model and type.
- If removing the valve from the line is not practical, as a crude remedy the disc can be placed into a position in the seat at which the leakage stops and travel stops are adjusted to this position.

TOTAL NUMBER OF STEM SEALS

Valve Size In. (mm)	Class 150	Material CF/G	Class	
			300	300
2.5	(65)	4	2 / 2	4
3	(80)	4	2 / 2	4
4	(100)	4	2 / 2	4
5	(125)	4	2 / 2	4
6	(150)	4	2 / 2	4
8	(200)	5	2 / 3	5
10	(250)	5	2 / 3	5
12	(300)	5	2 / 3	5
14	(350)	6	2 / 4	8
16	(400)	6	2 / 4	9
18	(450)	9	2 / 7	9
20	(500)	9	2 / 7	9
24	(600)	10	2 / 8	8

CF = Carbon Fiber G = Formed Graphite

GLAND NUT TORQUE Lb-in (N-m)

Valve Size In. (mm)	Class 150	Class			
		300	300		
2.5	(65)	35	(4)	45	(5)
3	(80)	35	(4)	45	(5)
4	(100)	35	(4)	45	(5)
5	(125)	45	(5)	65	(7)
6	(150)	45	(5)	65	(7)
8	(200)	45	(5)	80	(9)
10	(250)	65	(7)	100	(11)
12	(300)	65	(7)	100	(11)
14	(350)	80	(9)	125	(14)
16	(400)	100	(11)	150	(17)
18	(450)	100	(11)	150	(17)
20	(500)	100	(11)	150	(17)
24	(600)	150	(17)	200	(23)

MK Series - Operation and Maintenance Instructions

PARTS DIAGRAM - STANDARD

No.	Description
1.	Body
2.	Disc
3.	Stem
4.	Soft Seat
5.	Seat Retainer
6.	Locating Plug
7.	Gasket
8.	Bearing
9.	Disc Spacer
10.	Drive Screw
11.	Identification Tag
12.	Thrust Washer
13.	Stem Seal Set
14.	Grounding Washer (optional)
15.	Stud
16.	Gland Ring
17.	Retaining Ring
18.	Lock Washer
19.	Hex Nut
20.	Mounting Bracket
21.	Cap Screw
22.	Taper Pin
23.	Gland Retainer
24.	Lock Washer
25.	Cap Screw

